

History of the Speed of Light (c)

Jennifer Deaton and
Tina Patrick
Fall 1996

Revised by David Askey
Summer RET 2002

Introduction

The speed of light is a very important fundamental constant known with great precision today due to the contribution of many scientists. Up until the late 1600's, light was thought to propagate instantaneously through the ether, which was the hypothetical massless medium distributed throughout the universe. Galileo was one of the first to question the infinite velocity of light, and his efforts began what was to become a long list of many more experiments, each improving the

Is the Speed of Light Infinite?

- Galileo's *Simplicio*, states the Aristotelian (and Descartes)
 - *“Everyday experience shows that the propagation of light is instantaneous; for when we see a piece of artillery fired at great distance, the flash reaches our eyes without lapse of time; but the sound reaches the ear only after a noticeable interval.”*
- Galileo in *Two New Sciences*, published in Leyden in 1638, proposed that the question might be settled in true scientific fashion by an experiment over a number of miles using lanterns, telescopes, and shutters.

1667 Lantern Experiment



- The Accademia del Cimento of Florence took Galileo's suggestion and made the first attempt to actually measure the velocity of light.
 - Two people, A and B, with covered lanterns went to the tops of hills about 1 mile apart.
 - First A uncovers his lantern. As soon as B sees A's light, he uncovers his own lantern.
 - Measure the time from when A uncovers his lantern until A sees B's light, then divide this time by twice the distance between the hill tops.
- Therefore, the speed of light would theoretically be $c = (2D)/t$.

▪ Human reaction times are approx. 0.2 sec and therefore, too slow to determine c with any accuracy.

▪ Proved speed of light was finite and showed that light travels at least 10x faster than sound.

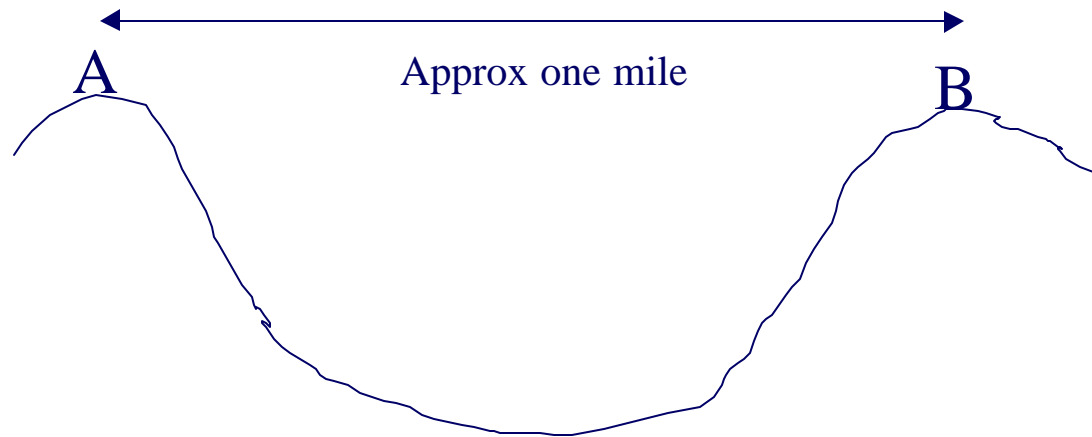

Longitude and Jupiter's Moons

- Thousands of men were lost at sea because there was no accurate way of determining longitude at sea.
- Galileo proposed using an eclipse of one of Jupiter's moons to determine the difference in longitude between two places.
- took up the task of using Jupiter's moon's to determine longitude.

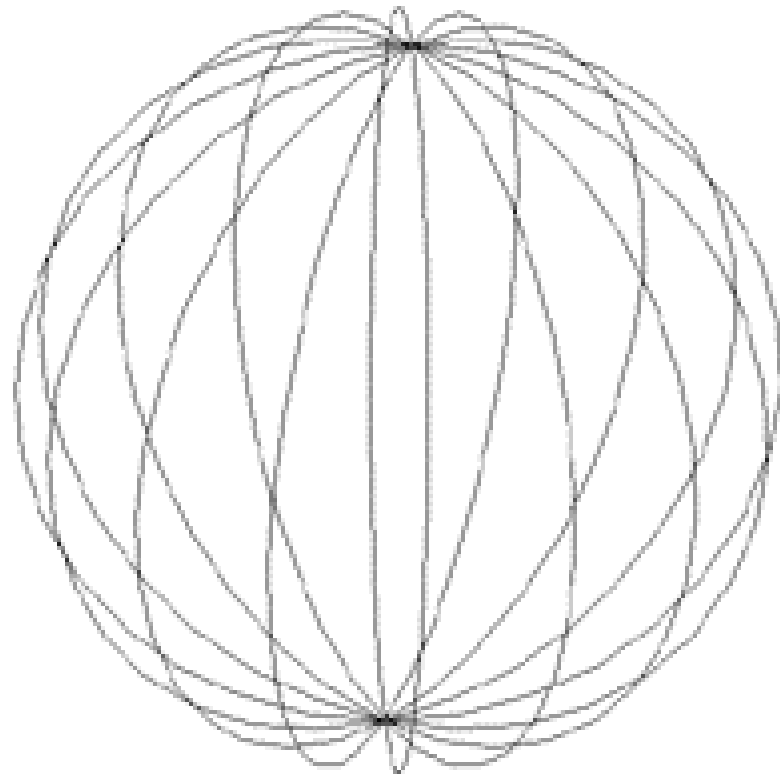

1676: First “Hard Evidence” For the Finite Speed of Light

- Olaf Roemer noticed variations in the eclipse times of Io, the innermost moon of Jupiter.

- When the Earth moved away from Jupiter, the moon appeared to stay behind the planet 22 minutes longer than when the Earth was moving towards Jupiter.

He used the equation: $c = (d_1 - d_2)/(t_1 - t_2)$

- t_2 = time of eclipse when the Earth is moving toward Jupiter
- t_1 = time of eclipse when the Earth is moving away
- d_2 = distance the Earth moves during t_2 .
- d_1 = distance the Earth travels during time t_1 ,

- Roemer determined that $c = 2.1 \times 10^8$ m/s.

- One third too slow because he was using inaccurate information on the radius of the Earth's orbit

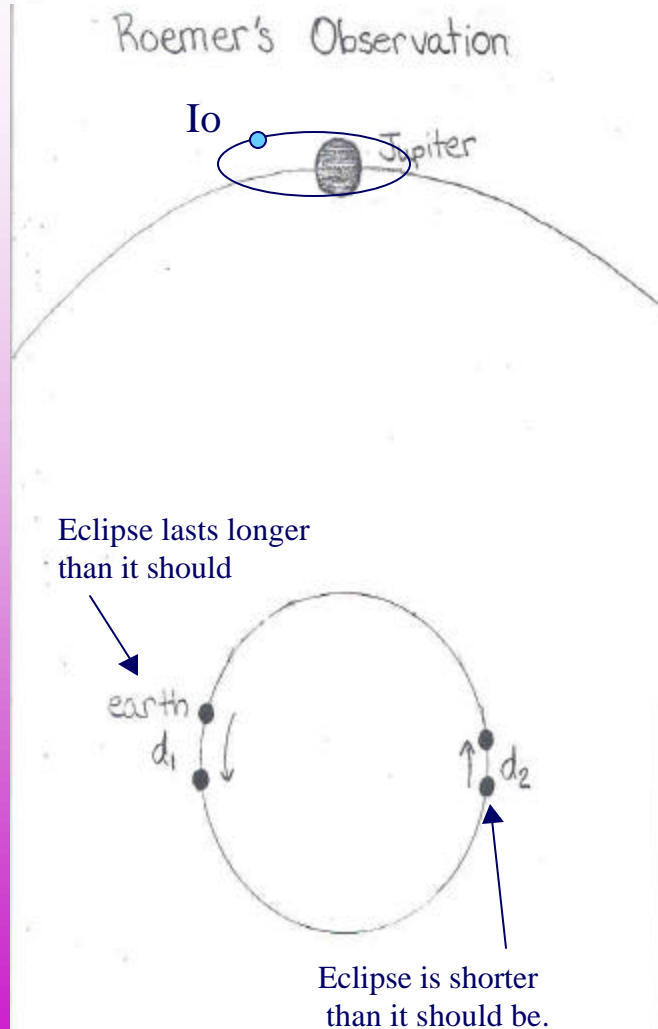

1728 Bradley and Stellar Aberration

- The stellar aberration is approximately the ratio of the speed the earth orbits the
- Stellar aberrations cause apparent position of stars to change due to
- Bradley used stellar aberration to calculate the speed of light by knowing:
 - speed of the earth around the sun.
 - the stellar aberration angle.
- His independent confirmation, after 53 years of struggle, finally absolutely ended the opposition to a finite value for the speed of light
- He calculated speed of light in a vacuum as $c = 301\,000$ km/s.

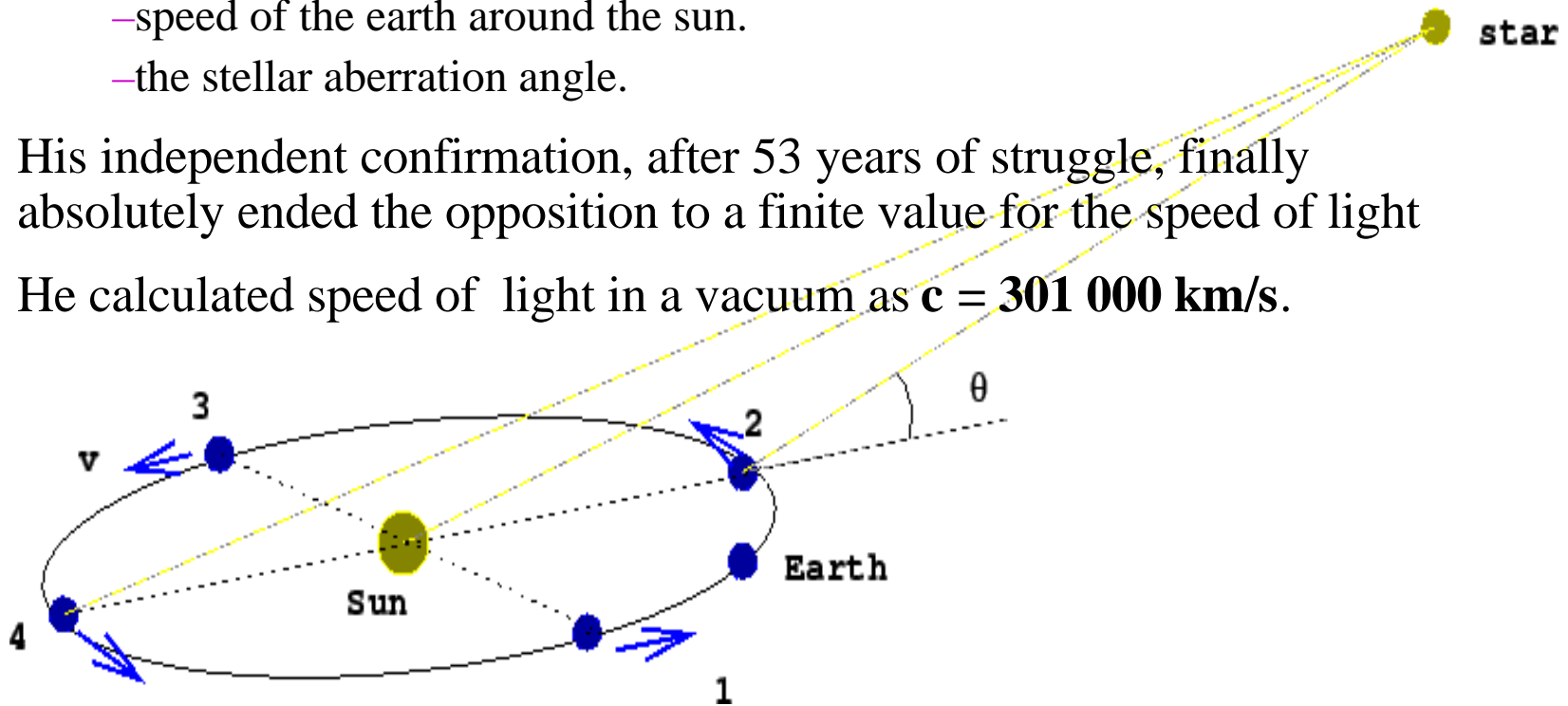

Fizeau's 1849 Cogwheel Experiment

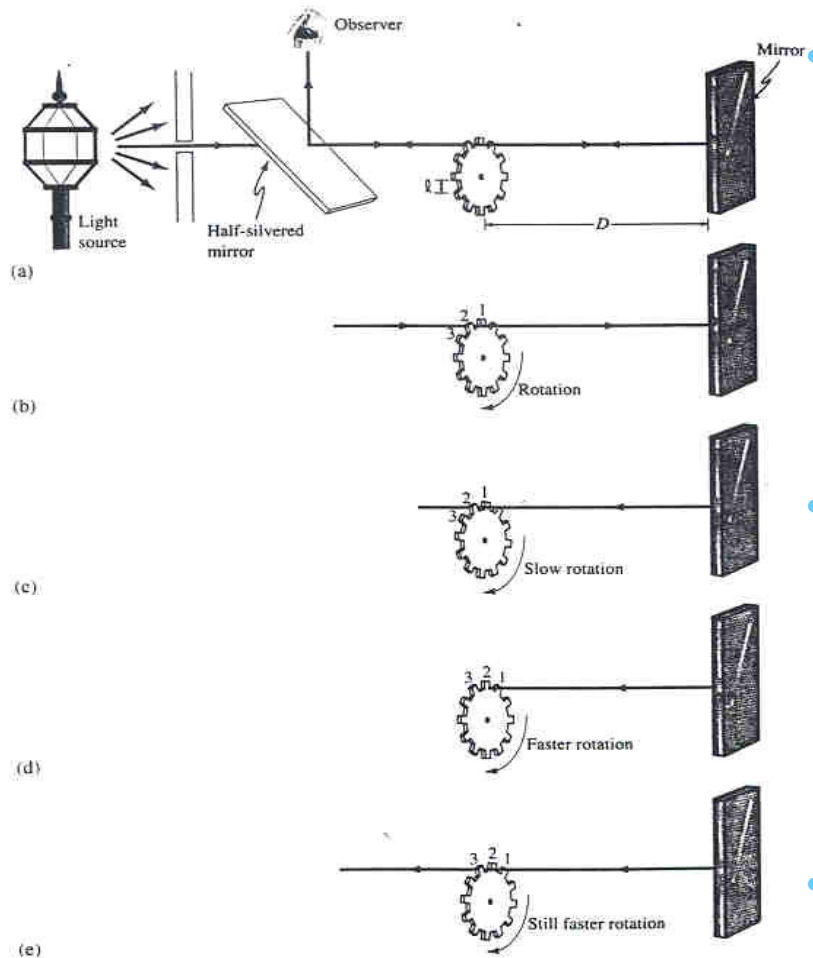

- used a slit to produce a narrow beam of light
- light travels through the spaces of a cogwheel
-
- he adjusted the rotational speed of the cogwheel until the light passes through the next space on the wheel.

- c can be calculated using the following:

$$c = (2D * v)/d$$

- D = distance between the wheel and the mirror
- v = the velocity of the wheel
- d = the distance between spaces on the wheel

- Using this method, Fizeau determined that $c = 3.15 \times 10^8$ m/s.

Fizeau's Cogwheel

Fizeau's 1851 Water Experiment

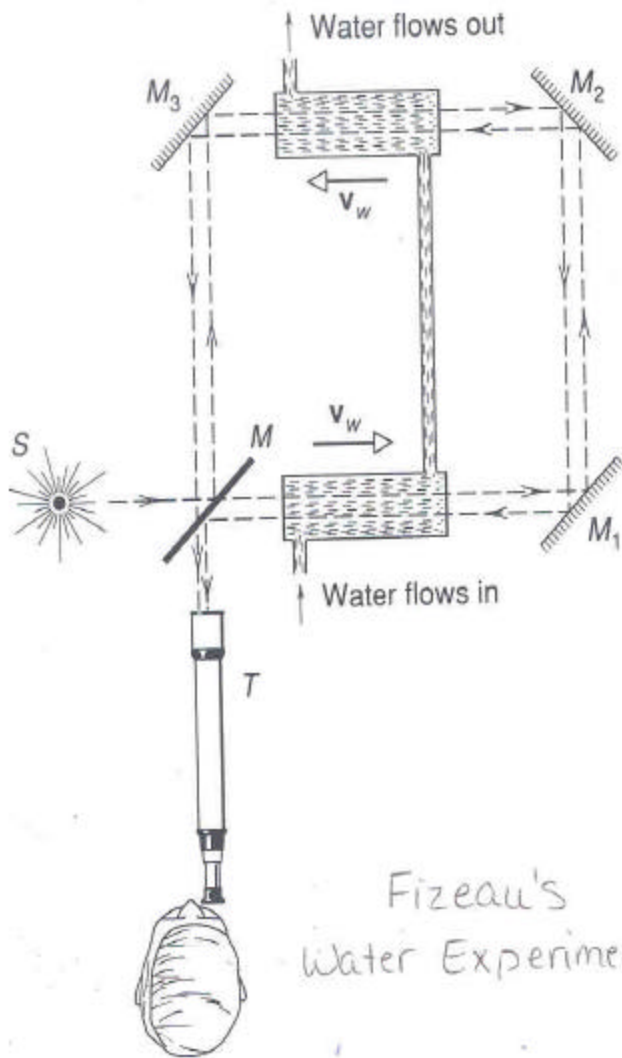

- Mirrors send a beam of light along two different paths through moving water.
- One of the paths is in the same direction as the v_w , other path was opposed to the v_w .
- When the two paths are looked at together they produce interference patterns. Speed of light through medium is determined from these patterns.
- Velocity of light in a medium is c/n , where n is the index of refraction.
- prediction that if the medium was moving an observer would measure the speed of
$$v(\text{light}) = (c/n) + v_{\text{med}}(1-1/n^2)$$
- If $n=1$, as in a vacuum, the velocity remains
- Leads to the invariance of the c in different reference frames, a very important fact in relativity.

Maxwell's 1865 Theoretical Conclusion

$$\text{Gauss's Law: } \oint \mathbf{B} \cdot d\mathbf{A} = 0 \quad ; \quad \text{Ampere's Law: } \oint \mathbf{B} \cdot d\mathbf{s} = \mu_0 I_{\text{enclosed}} + \mu_0 \epsilon_0 \frac{d\Phi_E \text{ enclosed}}{dt} .$$

- These equations have been tested for well over a century now, and as far as we know, they are correct and complete. Their most spectacular prediction is that changing electric and magnetic fields can produce each other by propagating as waves through space.
- Maxwell's equations **predict** that these waves should travel at a speed which just happens to be the speed of light. He used the following $c = 1/\sqrt{\epsilon\mu}$
- Maxwell's theory held that light is an electromagnetic oscillation, as are radio waves, microwaves, infrared waves, X-rays, and gamma rays.

$$\text{Gauss's Law: } \oint \mathbf{E} \cdot d\mathbf{A} = \frac{q_{\text{enclosed}}}{\epsilon_0} \quad ; \quad \text{Faraday's Law: } \oint \mathbf{E} \cdot d\mathbf{s} = -\frac{d\Phi_B \text{ enclosed}}{dt} .$$

Foucault's Method Introduced in 1875

- Leon Foucault bounced light from a rotating mirror on to a stationary curved mirror. This light is then reflected off this mirror back to the rotating mirror.
- Light is then deflected by a partially silvered mirror to a point where it can easily be observed. As the mirror is rotated, the light beam will focus at some displacement from s in the figure. By measuring this displacement, c can be determined from Foucault's equation:
$$c = (4AD^2 \omega) / ((A + B) \Delta s)$$
 - D is the distance from the rotating mirror to the fixed mirror,
 - A is the distance from L_2 and L_1 , minus the focal length
 - B is the L_2 and the rotating mirror
 - ω is the rotational velocity of the mirror.

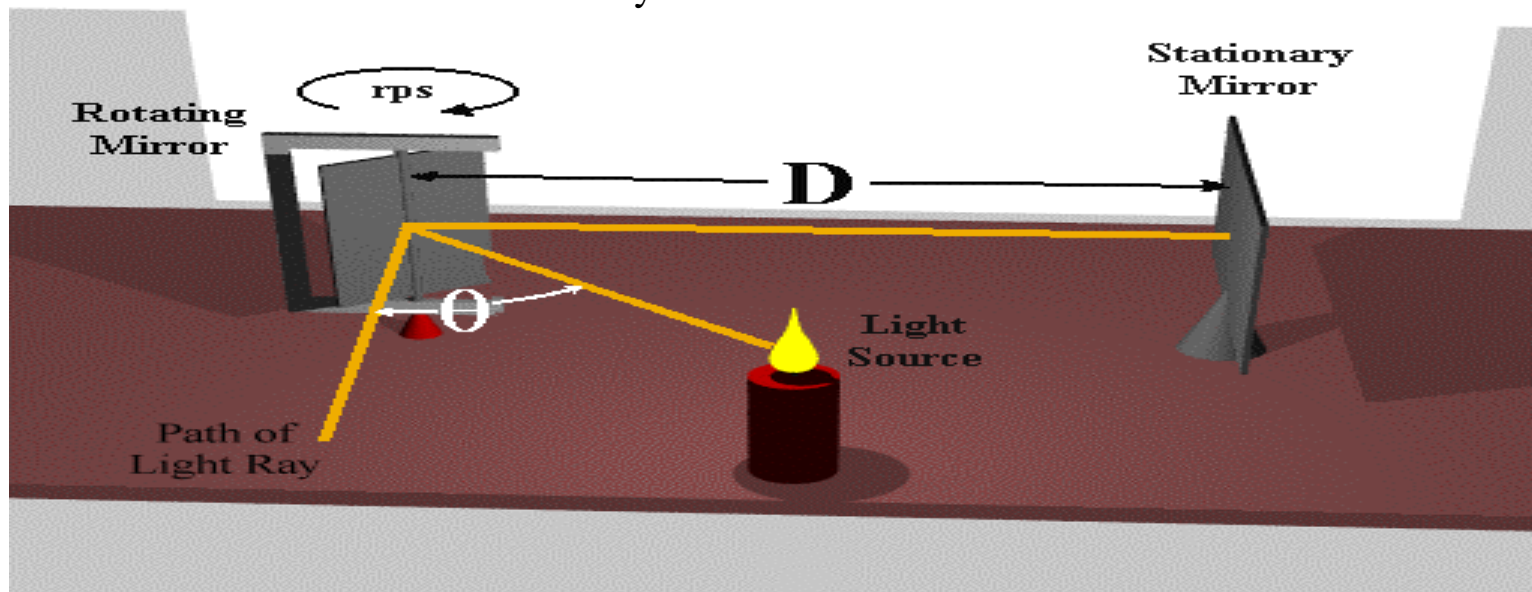

Michelson's 1878 Rotating Mirror Experiment

- German American physicist A.A. Michelson realized, on putting together Foucault's apparatus, that he could redesign it for much greater accuracy.
- Instead of Foucault's 60 feet to the far mirror, Michelson used 2,000 feet..
- Using this method, Michelson was able to calculate $c = 299,792 \text{ km/s}$
- . 20 times more accurate than Foucault
- . Accepted as the most accurate measurement of c for the next 40 years.

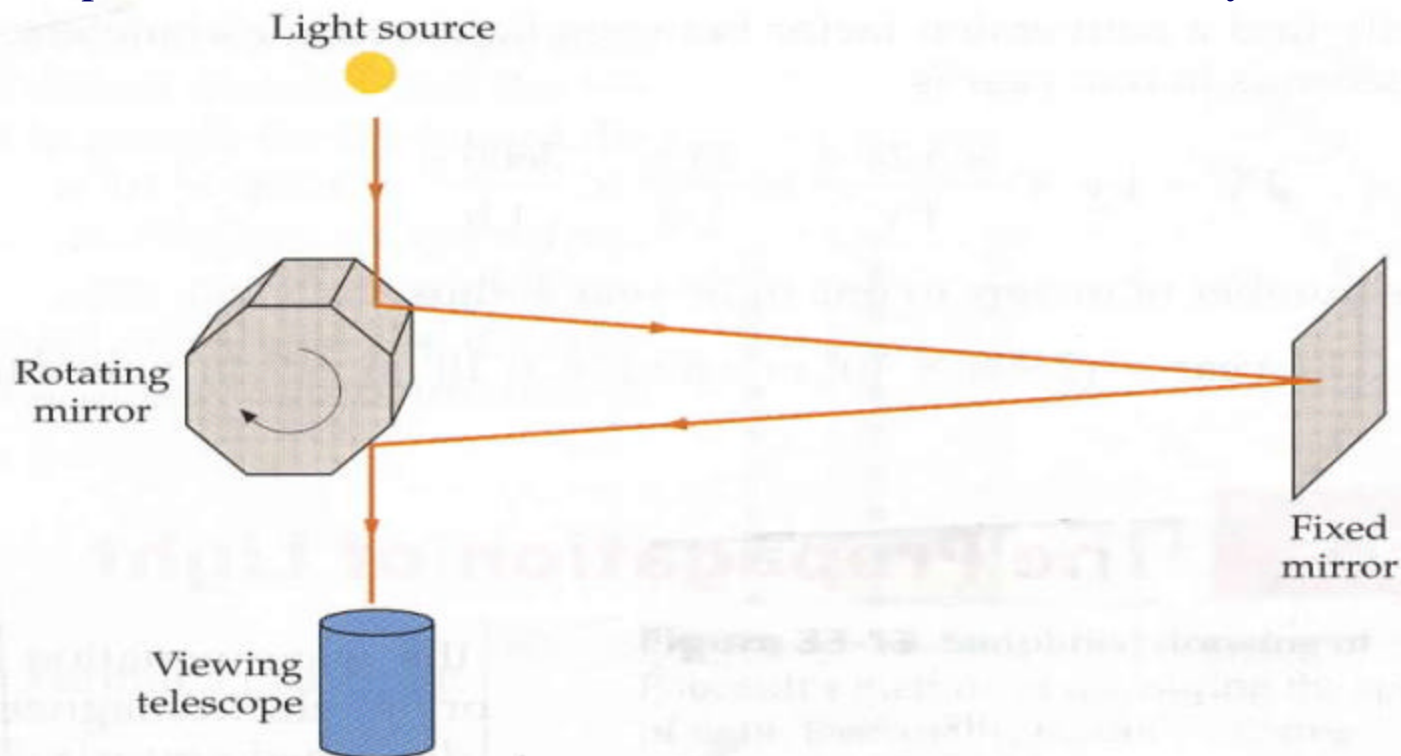

The Michelson Interferometer

- Monochromatic light split and sent it along 2 different paths to the same detector where the 2 waves will constructively or destructively interfere

- If one path is an integral number of half-wavelengths longer than the other, then the waves will interfere constructively and will be bright at the

- Otherwise, there will be alternating patches of light and dark areas called interference fringes.

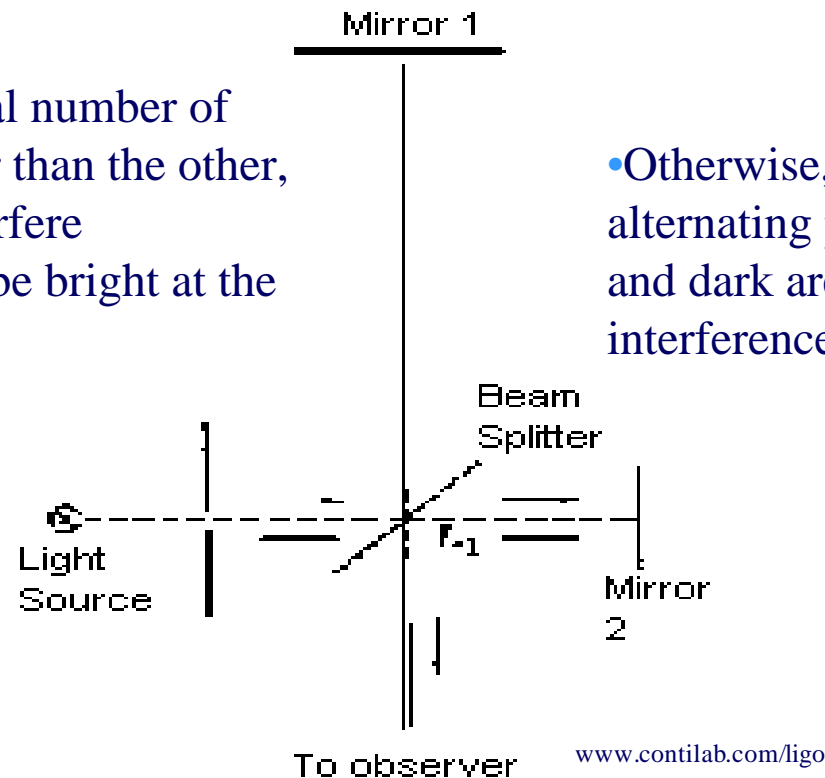

- The wavelength of the radiation in the interferometer can be determined from:

$$\lambda = 2L/N$$

-- L is the length increase of one path,

- N is the number of fringes observed during the increase.

1887 Michelson-Morley Experiment

Michelson and Morley experiment produced a null result in regards to

- Theoretical implications of this result is that the equations for the electromagnetic field must by their very nature reflect the indifference to the ether's
- This implies that Maxwell's equations must remain invariant under the transformation from one reference system to

QuickTime™ and a
Photo - JPEG decompressor
are needed to see this picture.

From Jack Meadows, *The Great Scientists*

1891: Blondlot's Parallel Wires

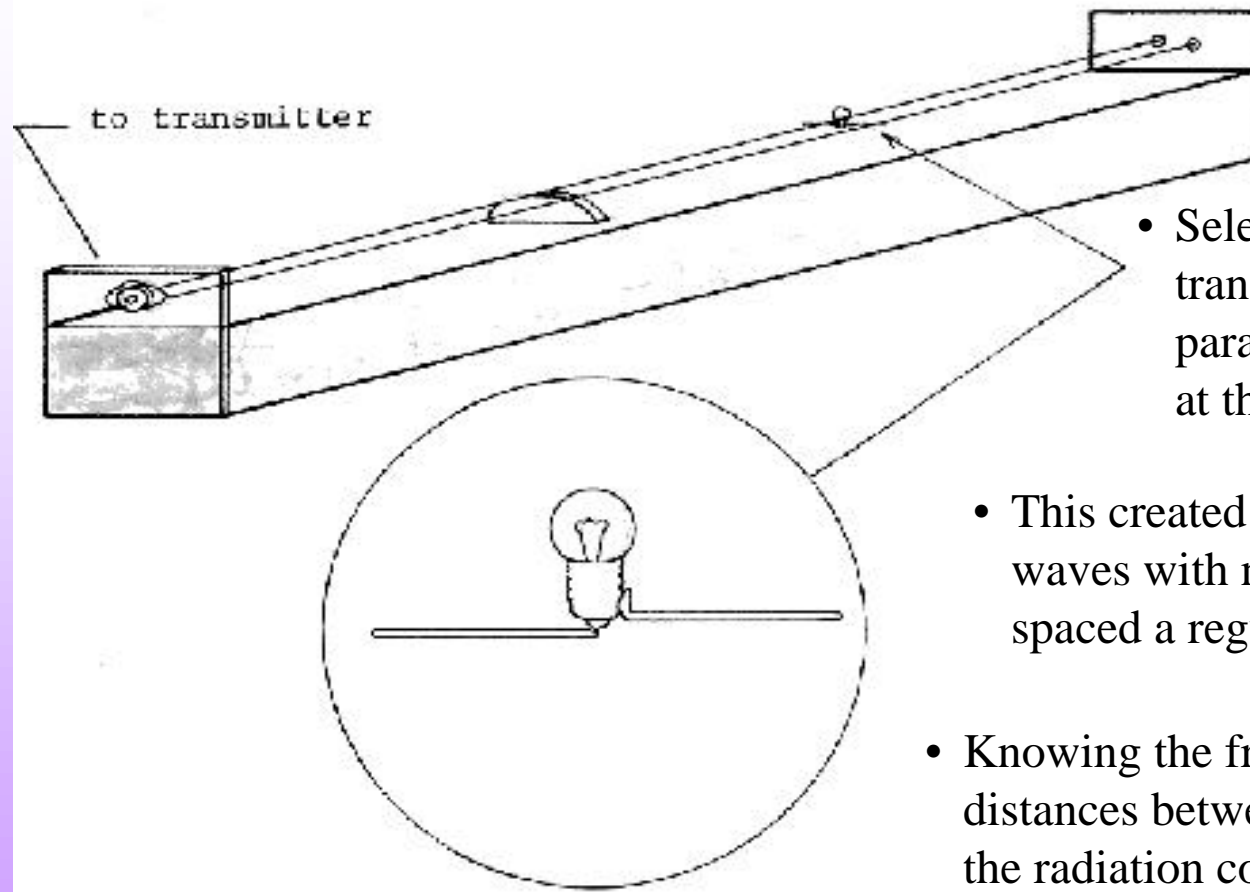

- Selected frequencies were transmitted along a pair of parallel wires and reflected at the far end.
- This created a system of stationary waves with nodes and antinodes spaced a regular intervals.
- Knowing the frequencies and the distances between nodes, the speed of the radiation could be determined.

$$c = 297,600 \text{ km/sec.}$$

L. Essen's 1950 Microwave Cavity Resonator

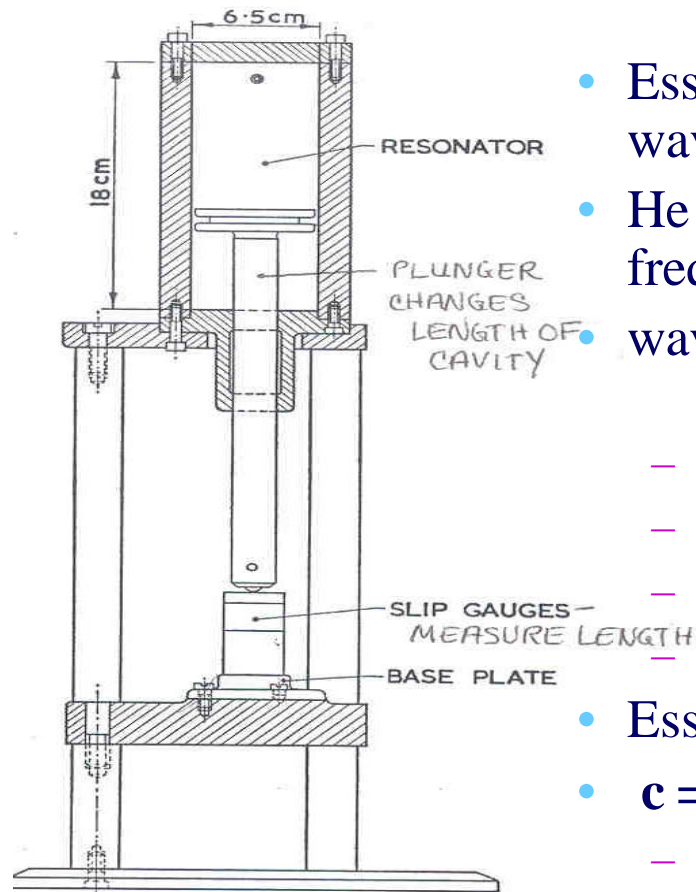

Fig. 6.6

Essen's Cavity Resonator

- Essen used radiation to produce standing waves in a closed hollow metal cylinder
- He produced radiation with resonant frequencies of 9.5 GHz, 9 GHz, and 6 GHz
- wavelength of the radiation in free space is

$$(1/\lambda)^2 = (\pi/D)^2 + (n/2L)^2$$
 - D is the diameter of the cylinder
 -
 - n is the # of half-wavelengths inside the cavity
 - λ is obtained from solving wave equations
- Essen used this method to determine c
- $c = 299,792.5 \pm 3 \text{ km/s}$ using $c = \lambda \nu$
 - ν is the resonant frequency
 - λ is the wavelength in free space.

Froome's 1958 Four-Horn Microwave Interferometer

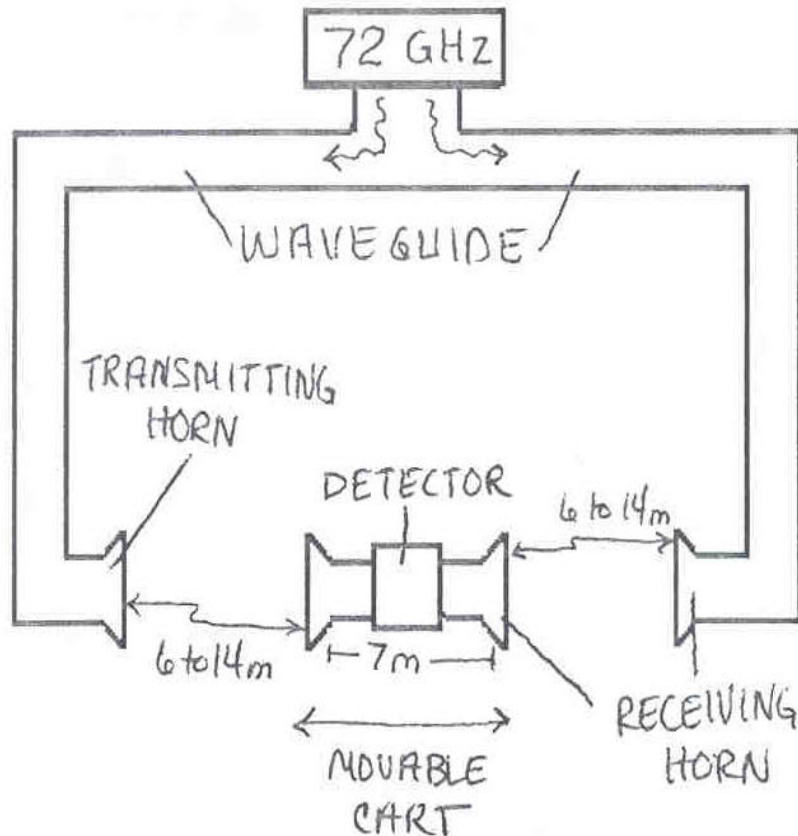

- Froome generated 72 GHz radiation and sent it through his interferometer.
 - Radiation divided into two beams, sent through two identical waveguides and out to two receivers on a movable cart.
 - Moving the receiver changed the path lengths of the two beams and caused interference in the
 - Every half-wave displacement in receiver, showed constructive interference.
- He determined the free space wavelength (λ) of the radiation by:

$$N \frac{c}{2} = \Delta z + A(1/z_1 - 1/z_2)$$
 - N is the number of interference minima
 -
 - $\Delta z = z_1 - z_2$ is the displacement of the cart.
- He calculated $c = 299,792.5 \pm 0.3$ km/s.

1983 Breakthrough by Boulder Group: Meter Redefined

- Signals synthesized at progressively higher and higher frequencies using harmonics generation and mixing methods to lock the frequency of a nearby oscillator or laser to the frequency of this synthesized signal.
- Photodiodes and metal-insulator-metal diodes used for harmonic generation
- A frequency chain was constructed linking a microwave output of the cesium frequency so the group could directly measure the frequency of a helium-neon laser stabilized against the 3.39 μm transition of methane.
- Resulted in a reduction in the uncertainty of speed of light by a factor of 100
- Formed basis for a new definition of the meter based on the speed of light.

“The meter is the length of the path traveled by light in a vacuum during the time interval of $1/299\,792\,458$ of a second.”.

- Led to the development of high resolution spectroscopic methods.

Historical Accuracy of speed of light

| Date | Experimenter | Country | Experimental Method | Speed (10⁸m/s) | Uncertainty (m/ true c) | Error from |
|-------------|---------------------|----------------|----------------------------|----------------------------------|--------------------------------|------------------------|
| 1600 | Galileo | Italy | Lanterns and shutters | "Fast" | ? | |
| 1676 | Roemer | France | Moons of Jupiter | 2.14 | ? | 28% |
| 1729 | Bradley | England | Aberration of Light | 3.08 | ? | 2.70% |
| 1849 | Fizeau | France | Cog Wheel | 3.14 | ? | 4.70% |
| 1879 | Michelson | United States | Rotating mirror | 2.9991 | 75000.0 | 400 in 10 ⁶ |
| | Michelson | United States | Rotating mirror | 2.99798 | 22000.0 | 18 in 10 ⁶ |
| 1950 | Essen | England | Microwave cavity | 2.997925 | 1000.0 | 0.1 in 10 ⁶ |
| 1958 | Froome | England | Interferometer | 2.997925 | 100.0 | 0.1 in 10 ⁶ |
| 1972 | Evenson et al. | United States | Laser Method | 2.99792457 | 1.1 | 2 in 10 ⁹ |
| 1974 | Blaney et. al | England | Laser Method | 2.99792459 | 0.6 | 3 in 10 ⁹ |
| 1976 | Woods et al. | England | Laser Method | 2.99792459 | 0.2 | 3 in 10 ⁹ |
| 1983 | | International | | 2.99792458 | 0.0 | Exact |

Classroom Application: Microwaving Marshmallows

- Without rotating trays and reflecting fan, microwave ovens cook unevenly.
- A pattern of standing waves forms inside the oven chamber.
- Creates an array of hotspots throughout the oven's volume.
- An operating frequency of 2450 MHz produces a wavelength of 12.2cm.
- Hotspots should be at **halfwave points**, or approximately every 6 cm, but in a complex 3D pattern.
- After about one minute on low power, a one layer sheet of small marshmallows should have melt spots that resemble the pattern behind this

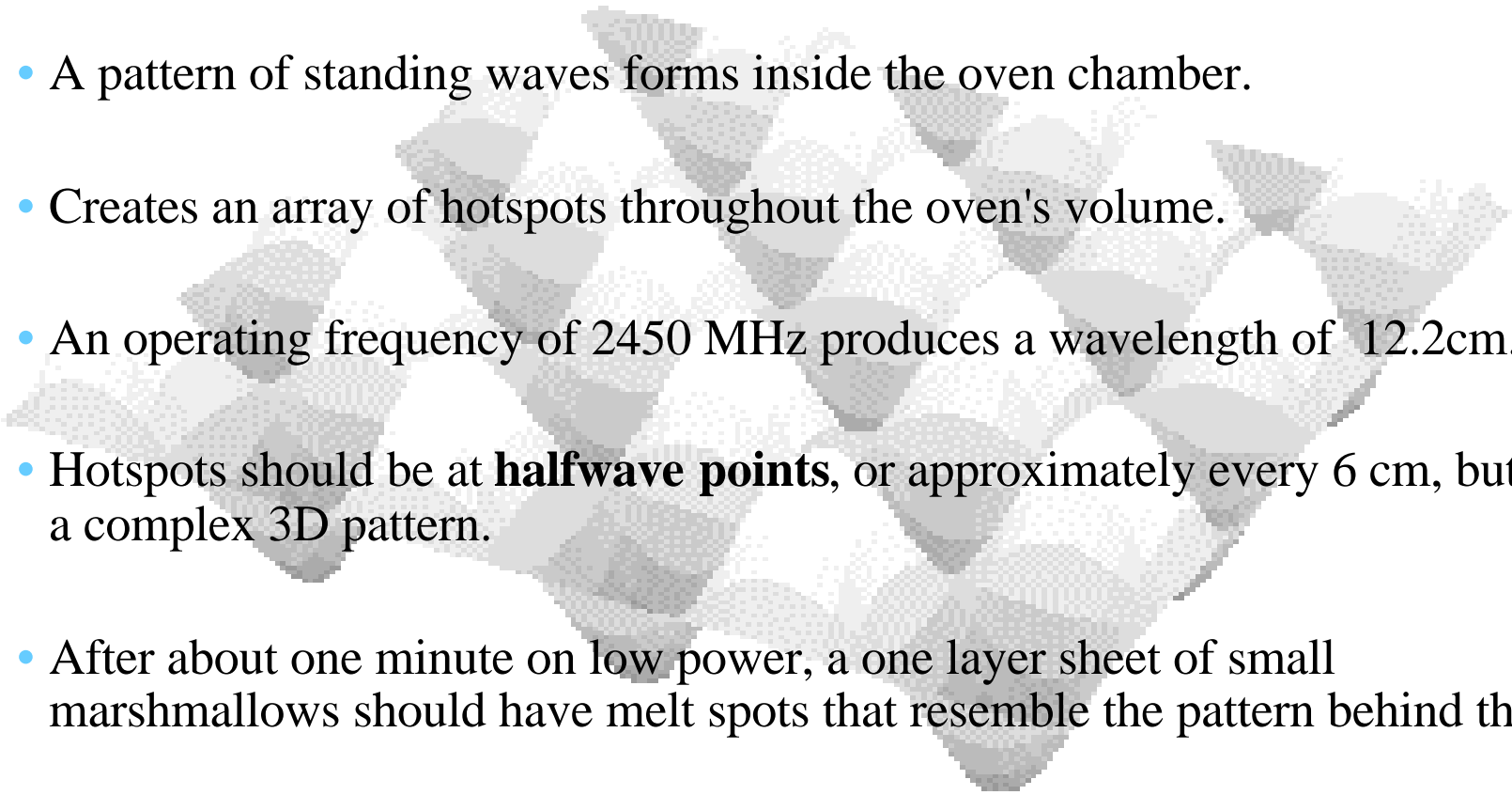

Conclusion

Why would so many scientists throughout the last four centuries spend so much of their careers to make an accurate measurement of the speed of light?

- A small error in c causes an enormous error in distance measurements to stars.**
- Einstein's theory of relativity would not be possible without first discovering that c is invariant in different reference frames.**
- These experiments eventually led to the redefinition of the meter**

Bibliography

- Fishbane, P., S. Gasiorowitz, and S. Thornton. Physics for Scientists and Engineers. New Jersey: Prentice Hall, 1993.
- Froome, K., and L. Essen. The Velocity of Light and Radio Waves. London: Academic Press, 1969.
- Halliday, D., R. Resnick, and J. Walker. Fundamentals of Physics. New York: John Wiley & Sons, 1993.
- Michelson, A. Experimental Determination of the Velocity of Light. Minneapolis: Lund Press, 1964.
- Mulligan, J. Introductory College Physics. New York: McGraw-Hill Book Co., 1985.
- Resnick, R., and D. Halliday. Basic Concepts of Relativity. New York: MacMillan Publishing Company, 1992.
- Serway, R.A., and Faughn J.S.. College Physics. Florida: Harcourt,Brace& Co., 1999
- The Illustrated Longitude. New York: Walker Publishing,
- Sullivan, D.B., Speed of Light From Direct frequency and Wavelength Measurements. Matt's Article he gave me on 7/22