

Pad Periphery Length

Signal I/O				
Pad Name	Type	Width (μm)	Spacing WB (μm)	Spacing BB (μm)
CCK_pad	Signal	125	150	300
CK_pad	Signal	250	300	300
DAO_pad	Signal	125	150	300
DCI_pad	Signal	250	300	300
DTI_pad(0)	Signal	250	300	300
DTI_pad(1)	Signal	250	300	300
DTI_pad(10)	Signal	250	300	300
DTI_pad(11)	Signal	250	300	300
DTI_pad(12)	Signal	250	300	300
DTI_pad(13)	Signal	250	300	300
DTI_pad(14)	Signal	250	300	300
DTI_pad(15)	Signal	250	300	300
DTI_pad(2)	Signal	250	300	300
DTI_pad(3)	Signal	250	300	300
DTI_pad(4)	Signal	250	300	300
DTI_pad(5)	Signal	250	300	300
DTI_pad(6)	Signal	250	300	300
DTI_pad(7)	Signal	250	300	300
DTI_pad(8)	Signal	250	300	300
DTI_pad(9)	Signal	250	300	300
DTO_pad(0)	Signal	250	300	300
DTO_pad(1)	Signal	250	300	300
LD_pad	Signal	125	150	300
LV1_pad	Signal	250	300	300
RSI_pad	Signal	125	150	300
RSO_pad	Signal	125	150	300
STRO_pad	Signal	250	300	300
SYNC_pad	Signal	250	300	300
XCKIN_pad	Signal	250	300	300
XCK_pad	Signal	250	300	300
Total (μm)		7575	8950	9700

Test Signal				
Pad Name	Type	Width (μm)	Spacing WB (μm)	Spacing BB (μm)
REF				
TSTIN_pad	Test	125	150	300
TSTOUT_pad	Test	125	150	300
TSTENO_pad	Test	125	150	300
TSTEN1_pad	Test	125	150	300
Total (μm)		500	600	1200

Power & Ground				
Pad Name	Type	Width (μm)	Spacing WB (μm)	Spacing BB (μm)
GND_0	Ground	125	150	300
GND_1	Ground	125	150	300
GND_2	Ground	125	150	300
GND_3	Ground	125	150	300
GND_4	Ground	125	150	300
VDD_0	Power	125	150	300
VDD_1	Power	125	150	300
VDD_2	Power	125	150	300
VDD_3	Power	125	150	300
VDD_4	Power	125	150	300
Total (μm)		1250	1500	3000

Corners				
Pad Name	Type	Width (μm)	Spacing WB (μm)	Spacing BB (μm)
corner_1	Corner	350	350	350
corner_2	Corner	350	350	350
corner_3	Corner	350	350	350
corner_4	Corner	350	350	350
Total x 2 (μm)		2800	2800	2800

Transparent Mode				
Pad Name	Type	Width (μm)	Spacing WB (μm)	Spacing BB (μm)
LDT_pad	TM	125	150	300
LV1T_pad	TM	250	300	300
TM_pad	TM	125	150	300
SYNCT_pad	TM	250	300	300
CCKT_pad	TM	125	150	300
STRL_pad	TM	250	300	300
Total (μm)		1125	1350	1800

3 options:

- Minimum size:
→ 11.425 mm
- WB parallel (150 μm)
→ 13.150 mm
- MCC flip (300 μm)
→ 16.000 mm

NB.: Transparent mode not implemented

Flex Hybrid Module Envelope

Revision 4 of 2/2/2001

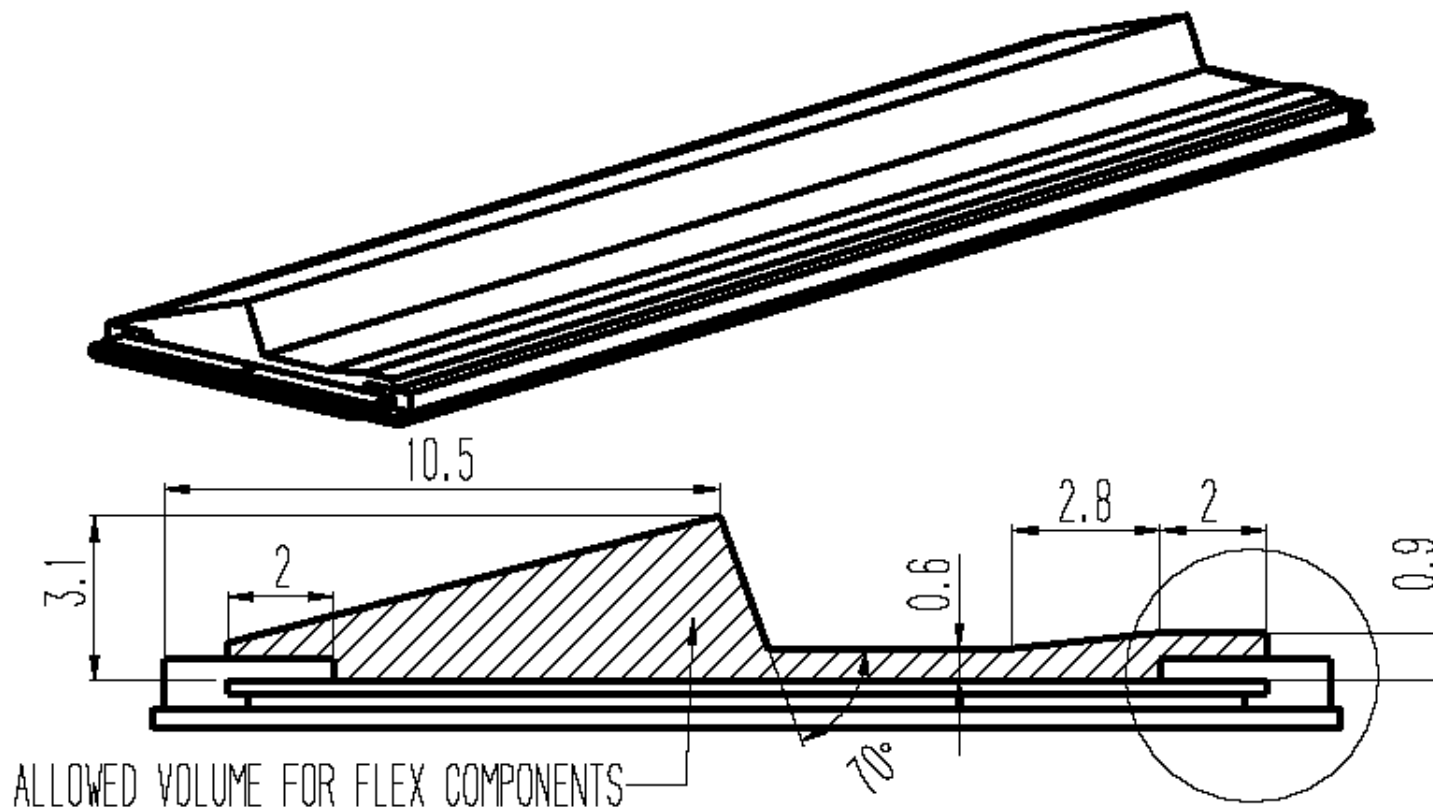



WB Allowed Region & MCC Sizes/Aspect Ratios

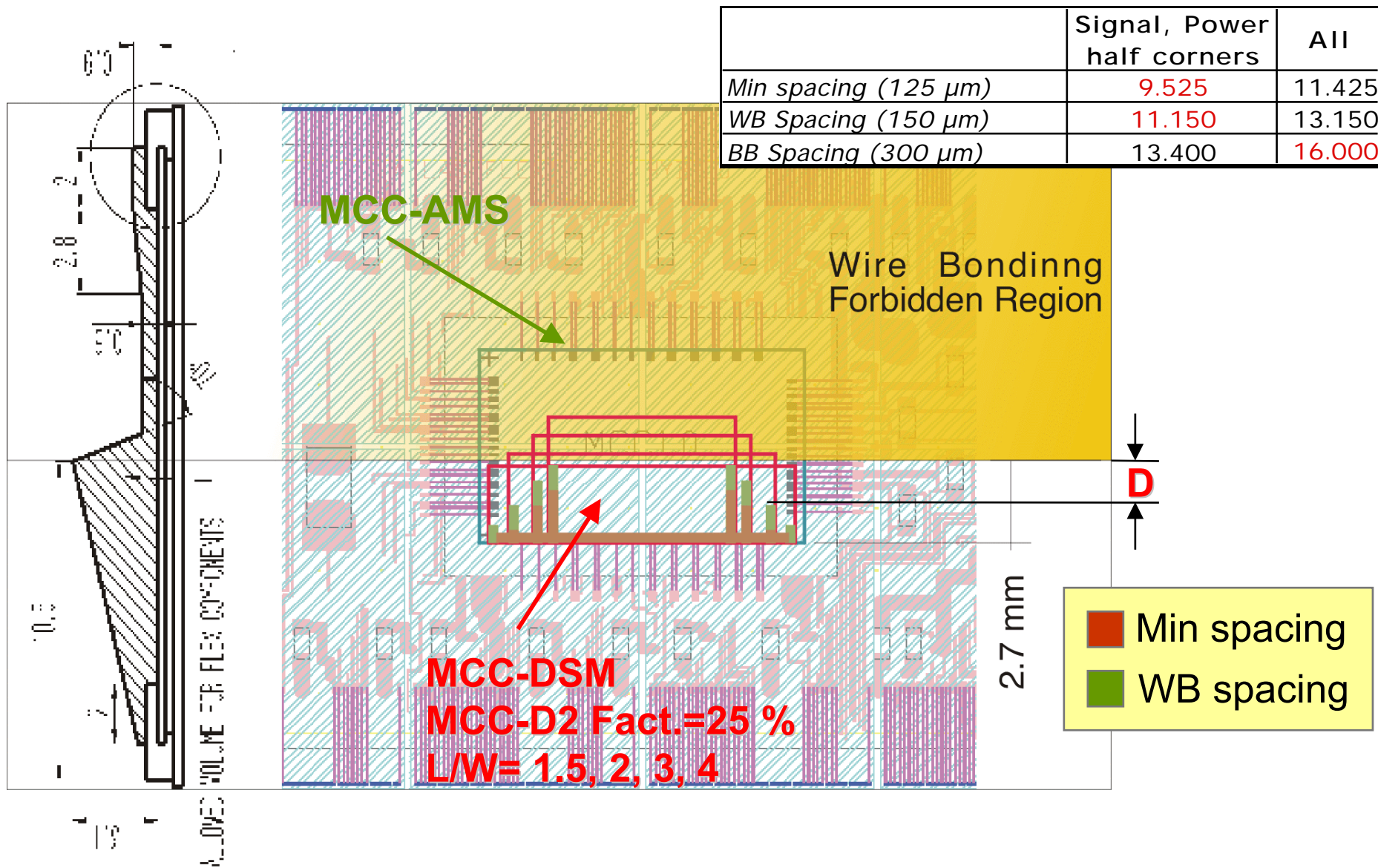



U-Shaped Wire Bonding

- Value of **D** parameter for 125 mm (D Min) & 150 μm (D WB) wire-bonding spacing.
 - ↳ **D** is the distance the last wire-bonding pad, on the MCC short sides, from the forbidden component region on the Flex (see figure)
- Pad to be wire bonded are: **Signal, Power & Ground.**

MCC-D2 Fraction	Area mm ²	L/W	Length mm	Width mm	Perim mm	D Min mm	D WB mm
33 %	33	1.5	7.0	4.7	23.5	1.5	0.6
33 %	33	2	8.1	4.1	24.4	2.0	1.2
33 %	33	3	9.9	3.3	26.5	2.7	2.1
33 %	33	4	11.5	2.9	28.7	2.7	2.7
25 %	25	1.5	6.1	4.1	20.4	1.0	0.2
25 %	25	2	7.1	3.5	21.2	1.5	0.7
25 %	25	3	8.7	2.9	23.1	2.3	1.5
25 %	25	4	10.0	2.5	25.0	2.7	2.1
20 %	20	1.5	5.5	3.7	18.3	0.7	-0.1
20 %	20	2	6.3	3.2	19.0	1.1	0.3
20 %	20	3	7.7	2.6	20.7	1.8	1.0
20 %	20	4	8.9	2.2	22.4	2.4	1.6



MCC-DSM with AMS Compatible Pinout

- MCC-DSM and MCC-AMS
- MCC-DSM only
- MCC-AMS only
- Test

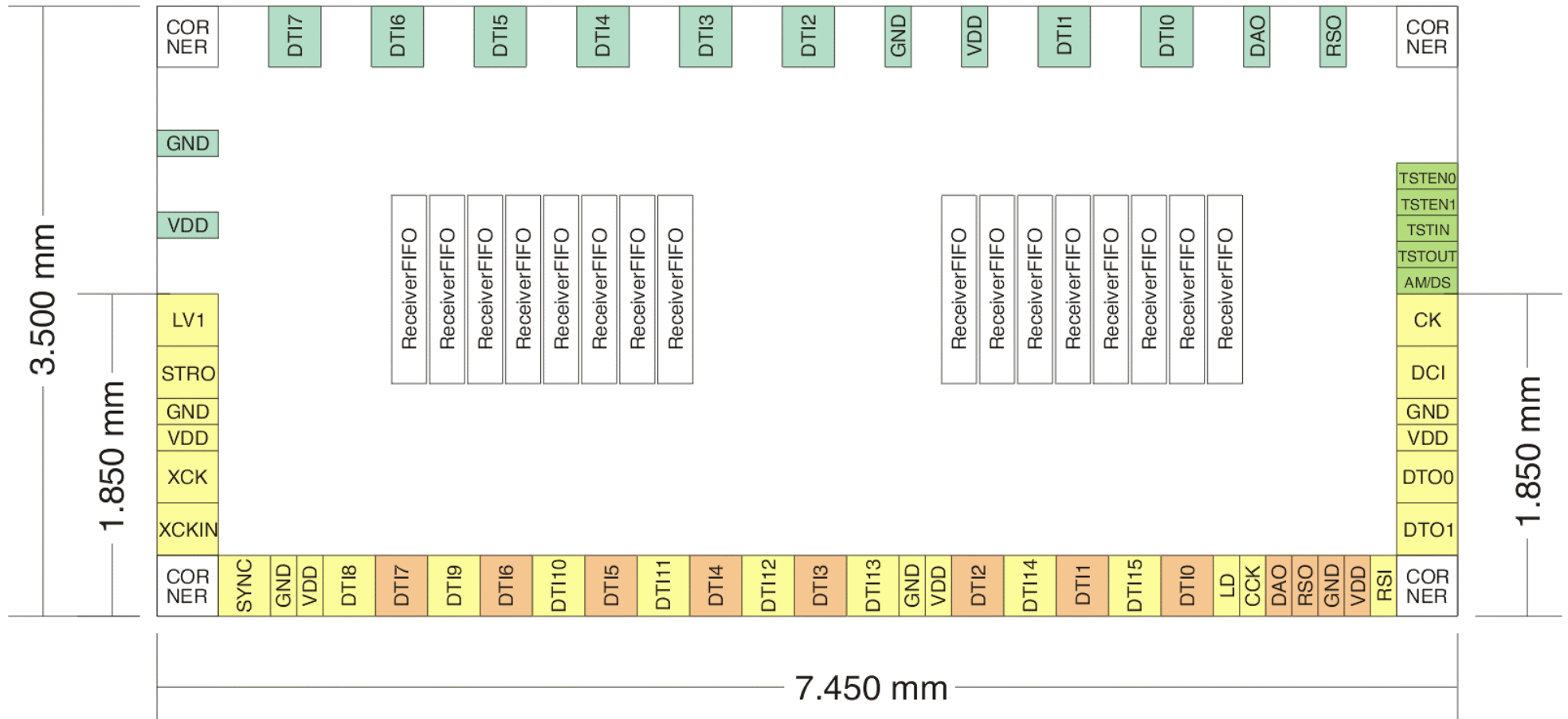

MCC-DSM Wire Bonded to FH2.x

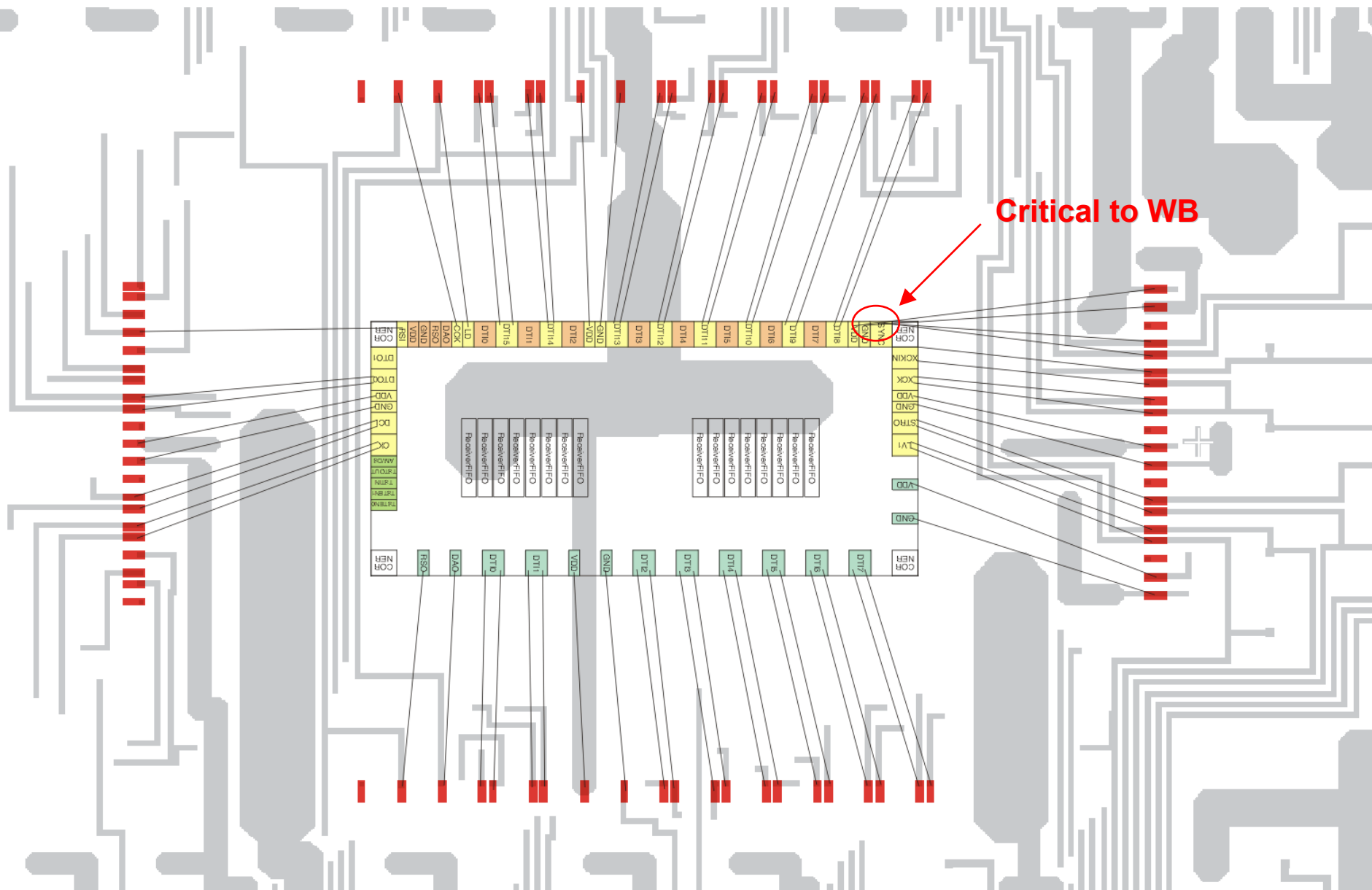

MCC-DSM: Pad Order

- MCC-DSM has U-shaped pads for ATLAS envelope flex hybrid:
 - It goes right up on flex hybrids respecting experiment mechanical envelope ,
 - It must be turned upside down (like MCC_AMS) on Flex2.x, 3.x.

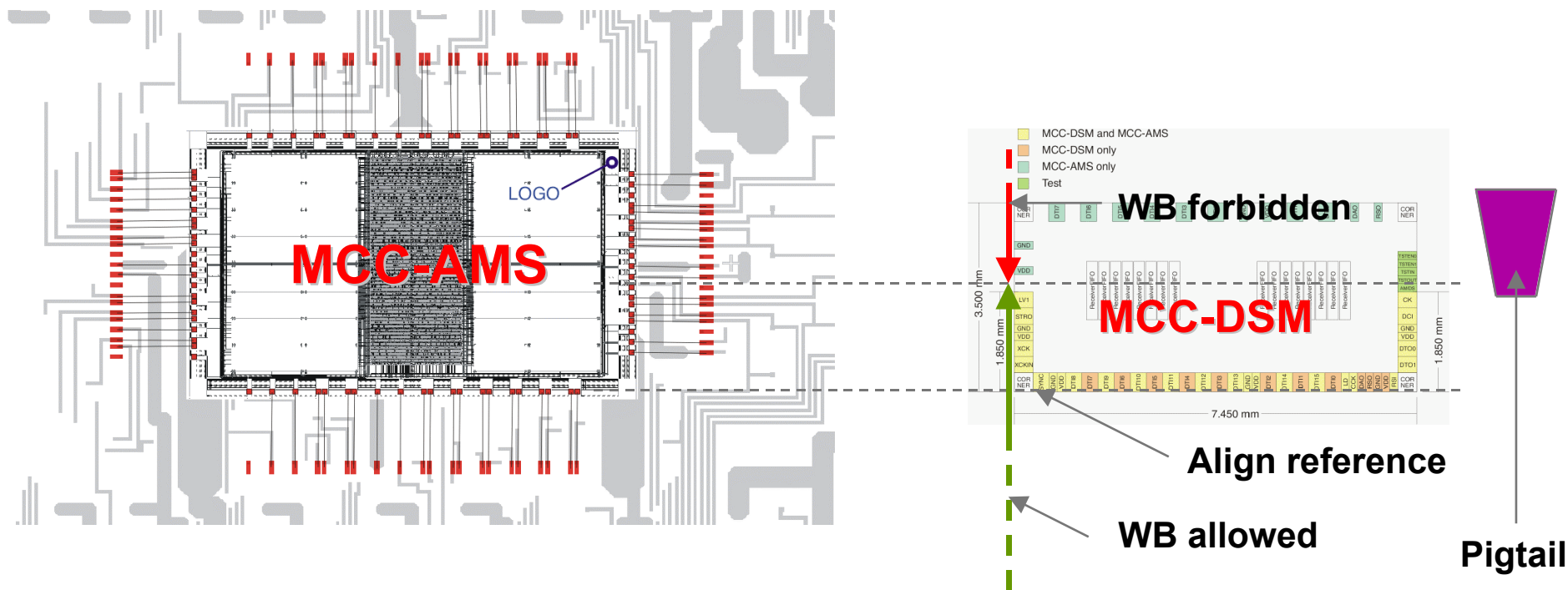



Other Considerations

- The two pinout modes: AMS-like and U-shape can be selected by a programmable pin (AM/DS) having a pull-up resistor or alternatively by selecting a bit in the CSR register;
- The U-shaped pinout has a clearance of > 1 mm from the forbidden component's region (if the bottom of the MCC-DSM is where the MCC-AMS on Flex 2.x is now) ;
- The pinout is not compatible with the requirements of the chip flip on flex;
- The test pins (scan chain) are not compatible with any of the boards using MCC's in the 84-LDCC packages;
- The proposed pinout drops the Transparent Mode functions of the current MCC's;
- The Flex 3.x, even if it is compatible with the MCC-AMS, should implement the second DTO1 line;
- The SYNC and the two power pins on the left bottom corner are difficult to bond on the Flex Hybrid 2.x. The Flex Hybrid 3.x could make it simpler if considered in the design. In case the wire bonding would be too difficult only the SYNC may be connected and GND/VDD dropped at that corner.